



Mount Laurel Township

# Municipal Utilities Authority

Mailing Address-1201 South Church Street – Mount Laurel, NJ 08054

Engineering Office: 81 Elbo Lane – Mount Laurel, NJ 08054-9641

Phone: (856) 722-5900 ext. 117

Email: [engineering@mltmua.com](mailto:engineering@mltmua.com)

Fax: (856) 235-0816

### S-4/W-4

## Application for Water and/or Sewer Connections

**Application Fee \$25**

Application is hereby made to connect to the Water and/or Sewer System of the Mount Laurel Township Municipal Utilities Authority. Applicant is subject to the rules and regulations of the above Authority and does hereby consent that the said Authority shall have the right to shut off service at any time due to any unavoidable accident, emergency, for the purpose of making repairs, or the applicants not complying with the rules and regulations of the Authority.

### Section A: General Information

Service Applying For: **Irrigation**  **Fire Service**  **Water**  **Sewer**   
Type of Dwelling: **Private**  **Apartment Building**  **Commercial**  **Industrial**

Name of Owner: \_\_\_\_\_  
  **Last**  **First**  **Middle Initial**

Mailing Address: \_\_\_\_\_  
  **Street**  **City**  **State**  **Zip**

Owner's Telephone Number: \_\_\_\_\_

Location of Work: Address \_\_\_\_\_  
  **House Number**  **Street**

Mt. Laurel Township Block Number: \_\_\_\_\_ Mt. Laurel Township Lot Number: \_\_\_\_\_

### Section B: Domestic Water and Irrigation Service

Size of Water Meter: **5/8" Meter**  **2" Meter**   
**1" Meter**  **2" Compound Meter**   
**1-1/2" Meter**  **3" Compound Meter**

Plumber's Name: \_\_\_\_\_ Telephone Number: \_\_\_\_\_

Irrigation Company's Name: \_\_\_\_\_ Telephone Number: \_\_\_\_\_

Meter Charge (If Applicable) \$ \_\_\_\_\_ Date Paid \_\_\_\_\_

Water Connection Fee: \$ \_\_\_\_\_ Date Paid: \_\_\_\_\_

*If TWA & BWSE permits are not required, Connection Fees are due prior to approval of this application*

**Section C: Fire Service**

Size of Commercial Fire Service Line: \_\_\_\_\_ Size Of Residential Fire Service Line: \_\_\_\_\_  
*Fire service rates for billing are based on the size of the fire service/hydrant line.*

**Section D: Sanitary Sewer Service:**

Plumber's Name: \_\_\_\_\_ Telephone Number: \_\_\_\_\_

Sanitary Sewer Connection Fee: \$ \_\_\_\_\_ Date Paid: \_\_\_\_\_  
*Connection Fees are due at the Time of application*

Does Property Have City Water: Yes  No

If Answer to Above is "NO":

Do you wish to install a well meter (no charge for meter) in order to avoid being charged the maximum charge for sanitary sewer? Yes  No

**Section E: Commercial Properties:**

A CID-1 Form and CID-2 Form (if applicable) must be submitted with this application.

**Section F: Cost Sharing Reimbursement requirement:**

Every main installed by a developer is entitled to Cost Sharing Reimbursement per Resolution 1988-23

**Section G: Applicant Signature:**

*I understand that my plumber has to sign and return to the Authority the attached form entitled "Mount Laurel Township Municipal Utilities Authority Procedure for Installation of Service Lines/Main Taps," and that I have received the attached pages 1- 6 as the Water & Sewer Service Details for installation, and that my plumber will follow these details as instructed.*

\_\_\_\_\_/\_\_\_\_\_/\_\_\_\_\_  
*Signature Date*

\_\_\_\_\_  
*Print Name*

Permit Number \_\_\_\_\_

Date \_\_\_\_\_

# PROCEDURE FOR INSTALLATION OF SERVICE LINE AND MAIN TAPS

- Contractor and Owner are solely responsible for identifying, obtaining and completing all applications/permits/approvals/inspections required by other agencies.
- Mark-out of MUA and other utilities must be obtained through the NJ One Call (811) in accordance with State requirements prior to the start of the proposed work. Other utilities must be contacted directly to schedule mark outs. Be advised that mark out of MUA utilities is based on information supplied by others, not obtained by Authority Personnel. **Water and sewer mark outs should be considered approximate.**
- A **Pre-construction meeting must be scheduled with the Authority Engineering Dept.** after all of the utilities have been marked out. At least 48 hours' notice is needed in order to schedule the manpower. Main/utility locations, standard construction details, approved site utility layout, and emergency procedures are some of the topics that will be reviewed at the meeting. The contractor will also be advised of any other requirements or procedures.
- The proposed start of construction date must be approved by the Authority. Consideration will be given to personnel scheduling and operational issues. At least 48 hours' notice is required for review/approval. To expedite this process, it is recommended that you provide more than one start date for MUA consideration
- **After construction commences the contractor is advised that Authority Engineering Dept. will, without exception, have sole authority to make decisions regarding the work in progress if and when this work adversely affects the MUA system, operations, personnel, customers or the health, safety or welfare of the contractor employees or others.** Contractors completing work contrary to MUA direction shall be required to immediately correct the deficient work and/or shall not be permitted in the future to complete work on water or sewer facilities within our franchise area. The Authority reserves the right to take other action if appropriate, to resolve the issue.
- All work in the Public right-of-way or easements dedicated to the MUA must be approved by either the MUA's consulting engineer or Authority personnel before the line is put into service.
- The Customer must verify completion of the work to the Authority prior to the work being formally approved by the Authority thru issuance of a Certificate of Occupancy/Approval.

---

Property Address

---

Owner Name / Phone No. / Date

The following page is an itemized check list that must be completed prior to the issuance of a Building Permit Release/Certificate of Occupancy. A final inspection must be conducted by the Authority prior to going to the Township for final approvals. Any deficiencies that need to be corrected must be done so before the Authority issues a MUA Certificate of Occupancy Release Form.

## **CHECK-LIST FOR ADMINISTRATIVE COMPLETENESS**

All items on the following list must be completed prior to requesting a Certificate of Occupancy or Certificate of Approval from Mount Laurel Township.

### **Owner:**

- 1. Execute S4/W4 Application for Connection and S2/W2 Service Agreement;
- 2. Pay required connection fees;
- 3. Pay for meter and marker ball fees

### **Contractor:**

- 4. Execute S4/W4 Application for Connection
- 5. Obtain and review the current *Mount Laurel Township MUA Rules, Regulations and Standard Construction Details* located at [www.MLTMUA.com](http://www.MLTMUA.com) as it applies to applications, fees, coordination, construction, inspection, final approval process or is otherwise associated with the proposed construction.
- 6. Submit plan for connection including location of service lines, laterals, curb stops, clean outs, location of connection to the main and the meter location. Submit material cuts of all material/equipment to be used.
- 7. Obtain utility mark-out **NJ One Call (811)**
- 8. Schedule and attend an on-site Pre-Construction meeting with the appropriate MUA department(s) to obtain MUA approval to commence construction. Forty-eight (48) hours advance notice is required. Call the Engineering Department/Inspector at 856-722-5900 x115
- 9. Before leaving Pre-Construction meeting, obtain approved S4/W4 Application to commence sewer and/or water construction, along with an approved Building Permit Release for submittal to Mt Laurel Township Construction Office.
- 10. Complete work in conformance with all Authority Rules, Regulations and Standard Details and obtain MUA approval of construction completed. Correct any deficiencies prior to MUA approval for service.
- 11. Provide asbuilt drawings locating all of the installed items shown on the approved plan.

### **Owner:**

- 12. Requests acceptance as MUA customer and, if applicable, schedules installation of a meter by MUA. (Customer billing commences)
- 13. Request and obtain a signed MUA Certificate of Occupancy Release Form prior to submittal to Mount Laurel Township for a Certificate of Occupancy or Certificate of Approval.
- 14. After acceptance as an MUA customer, and installation of meter for service connections, the owner is authorized to use the new service.

Our signatures below verify that we have read, understand, and agree to the procedures listed and have reviewed the checklist items noted on page 1 and 2 above:

---

Name of Owner/Customer

Signature

Phone Number

---

Name of Plumber/Contractor

Signature

Phone Number

**Updated 12 March 2019**

M:\Projects\M180007\TYPDETS\SH1-24 DATE: APR 17, 2013 TIME: 8:13 AM

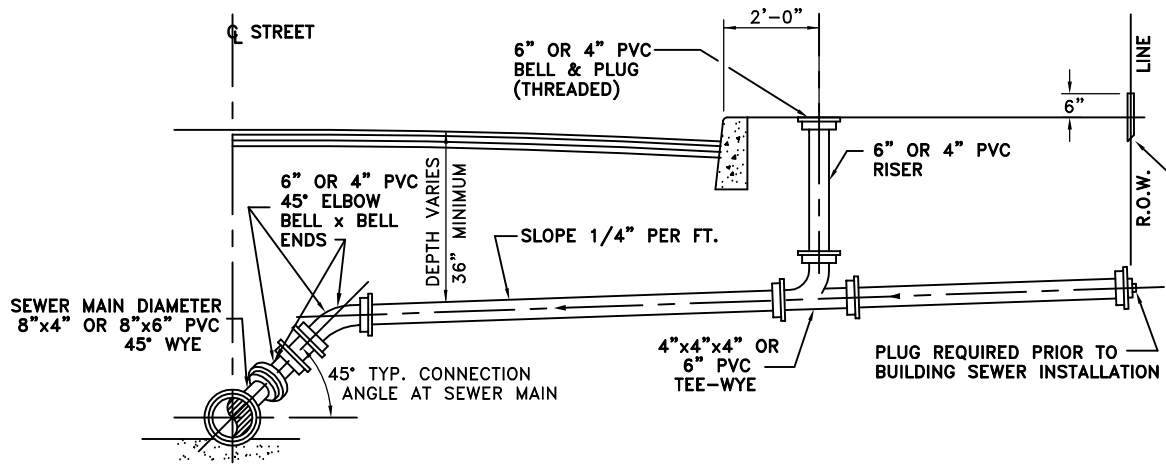

CONTRACTOR TO SET ONE(1)  
2"x4" STAKE OVER EACH  
LATERAL TO MARK END

**NOTES**

1. SANITARY SEWER LATERALS SHALL BE CONSTRUCTED OF PVC CONFORMING TO ASTM D-3034, SDR-35 FROM THE SANITARY SEWER MAIN TO THE CLEANOUT JUST BEHIND THE CURB LINE, AND FOUR-INCH (4") OR SIX-INCH (6") PIPE FROM THE CURB LINE TO THE HOUSE. ALL JOINTS SHALL BE PUSH-ON CONFORMING TO ASTM D-3212 WITH ELASTOMETRIC RING RUBBER GASKETS CONFORMING TO ASTM D-3212.
2. WHERE A PLUG IS PROVIDED ON RISER CLEANOUT, IT SHALL CONTAIN MAGNETIC MATERIAL SO THAT IT MAY BE LOCATED WITH A METAL DETECTOR.
3. CLEANOUTS SHALL NOT BE LOCATED IN SIDEWALKS OR DRIVEWAYS. IN NO CASE SHALL SANITARY SEWER LATERALS BE INSTALLED UNDER DRIVEWAYS.
4. SANITARY SEWER LATERALS SHALL BE INSTALLED AT A CONSTANT GRADE AND IN A STRAIGHT LINE. CLEANOUTS ARE REQUIRED EVERY 50' AND AT ANY CHANGE IN DIRECTION OF THE LATERAL.
5. THE MINIMUM DEPTH FOR A SANITARY SEWER LATERAL SHALL BE THIRTY-SIX INCHES (36").
6. TRACER WIRE IS REQUIRED FOR ALL PVC, HDPE OR NON-METALLIC LATERALS AND MUST BE INSTALLED ALL THE WAY TO THE BUILDING, TO ENABLE DETECTION BY A RADIO FREQUENCY CABLE AND PIPE LOCATOR. SEE TRACER WIRE NOTES FOR SPECIFICATIONS.

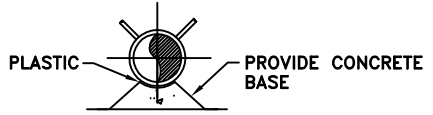

TAP EXISTING MAIN AT 11:00 OR 2:00 LOCATION. USE CAST IRON SADDLE CONFORMING TO ASTM SPEC. A-48 CLASS 35 AND COATED WITH BLACK ASPHALTUM TYPE PAINT. SADDLE SUPPLIED WITH ASTM D-1869-66 RUBBER O-RING CEMENTED IN PLACE. TWO (2) 24 GA. STAINLESS STEEL STRAPS, BRONZE T-BOLT, WASHER & HEX NUT. THE CONTRACTOR SHALL WRAP THE ENTIRE SADDLE WITH POLYETHYLENE IN ACCORDANCE WITH ANSI/AWWA C105/A21.5.

EXISTING MAIN CONNECTION

TRACER WIRE

- a. TRACER WIRE SHALL BE MINIMUM #10 AWG COPPER WIRE COATED WITH A MINIMUM 30 MIL POLYETHYLENE JACKET DESIGNED SPECIFICALLY FOR BURIED USE.
- b. TRACER WIRE SHOULD BE INSTALLED CONTINUOUSLY ALONG THE PIPE ROUTE WITH ACCESS POINTS PLACED EVERY 500 FEET OR AT TERMINATION OF ANY SECTION OF PIPE OR CONNECTION TO ANY EXISTING MAIN OR OTHER STRUCTURE. THE TRACER WIRE SHALL BE BROUGHT TO THE GROUND SURFACE AT ACCESS POINTS, SEE TRACER WIRE ACCESS POINT DETAIL. THE TRACER WIRE SHALL BE CONNECTED TO THE TRACER WIRE BOX LID AS RECOMMENDED BY THE MANUFACTURER. SPLICES IN THE TRACER WIRE SHOULD BE CONNECTED BY MEANS OF A HEAT SHRINK SPLICE KIT TO ENSURE CONTINUITY. WIRE NUTS SHOULD NOT BE USED.
- c. AFTER INSTALLATION, TRACER WIRE SHOULD BE TESTED TO VERIFY CONTINUITY OF THE TRACER WIRE SYSTEM AND A REPORT INDICATING CONTINUITY SHOULD BE SUBMITTED AS PART OF THE AS-BUILT CONSTRUCTION RECORDS.
- d. TRACER WIRE SHALL BE PLACED ON THE TOP SIDE OF THE PIPE. WIRE SHALL BE ATTACHED TO THE PIPE USING NYLON CABLE TIES SPACED AT TEN FOOT (10') INTERVALS.

|     |          |   |
|-----|----------|---|
| CFC | 12/05/18 | UPDATED TRACER WIRE NOTES                   |
| CFC | 6/07/18  | UPDATED THE NOTES                           |
| CFC | 6/01/18  | ELIMINATED NOTE 5                           |
| CFC | 12/15/17 | "SNAKEPIT BOX" DETAIL ADDED & NOTED UPDATED |
| CFC | 8/18/17  | ADDED NOTE 5                                |
| CFC | 2/12/16  | ADDED NOTE 4 & TRACER WIRE NOTES            |
| CFC | 5/20/15  | UPDATED SLOPE NOTE (1/4" PER FT. ONLY)      |
| CFC | 7/7/14   | ADD CLEAN-OUT TEE-WYE PER MLTJUA            |
| CFC | 11/12/09 | REMOVED ALTERNATE CONNECTION DETAIL         |
| BY  | DATE     | REVISIONS                                   |

**MOUNT LAUREL TOWNSHIP  
MUNICIPAL UTILITIES AUTHORITY**

**SANITARY SEWER  
TYPICAL LATERAL  
CONNECTION DETAIL**

|         |      |                |
|---------|------|----------------|
| DATE:   | 4/95 | SHEET NO.<br>3 |
| DWG BY: |      |                |

APPROVED EQUALS:

COMPRESSION CURB STOPS

- MUELLER CO. B-25209N
- A.Y. McDONALD MFG. CO. SERIES 76004-22

COMPRESSION CORPORATION STOPS

- MUELLER CO. B-25008N
- A.Y. McDONALD MFG. CO. SERIES 74101BCAP-22

CURB BOX TO BE BETWEEN CURB AND SIDEWALK UNLESS APPROVED OTHERWISE

MAXIMUM TAP SIZES

| MAIN SIZE | LARGEST DIRECT TAP SIZE |
|-----------|-------------------------|
| 6",8"     | 1"                      |
| 10"       | 1-1/2"                  |
| 12"       | 2"                      |

BOLTS, NUTS & WASHERS: 18-8 TYPE 304 STAINLESS STEEL

LIFTER BAR: 18-8 TYPE 304 STAINLESS STEEL

GASKET: BUNA-N (NBR)

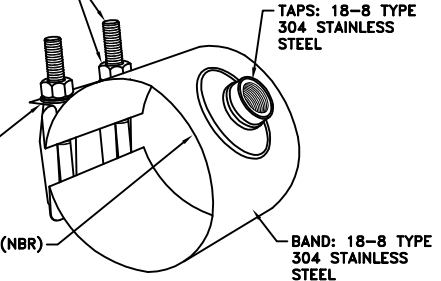

FORD STAINLESS STEEL  
SADDLE STYLE FS300

N.T.S.

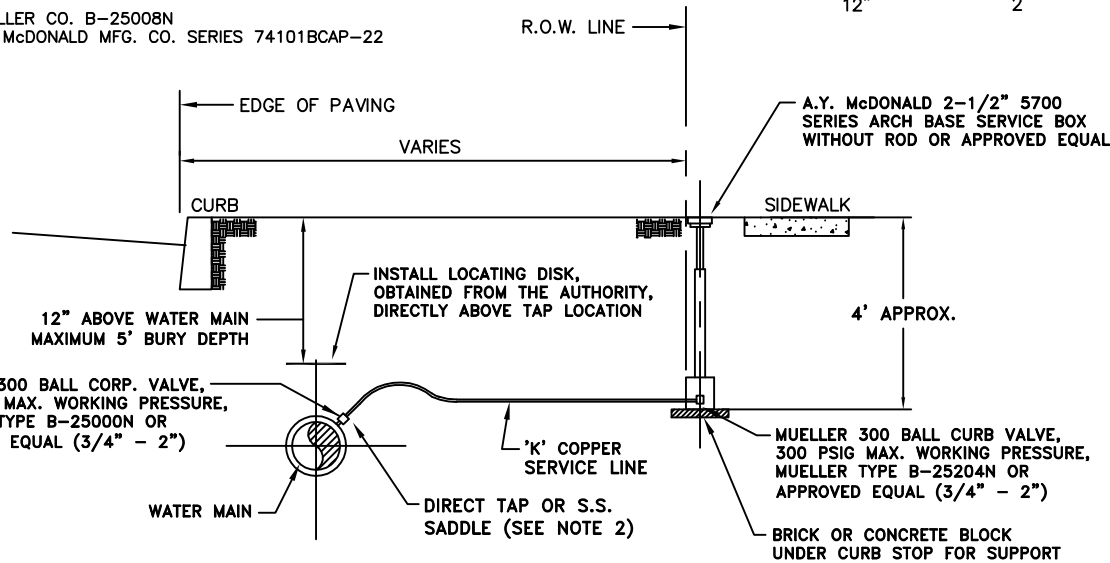

TRACER WIRE

- TRACER WIRE SHALL BE A MINIMUM #10 AWG COPPER WIRE COATED WITH A MINIMUM 30 MIL POLYETHYLENE JACKET DESIGNED SPECIFICALLY FOR BURIED USE.
- TRACER WIRE SHOULD BE INSTALLED CONTINUOUSLY ALONG THE PIPE ROUTE WITH ACCESS POINT PLACED EVERY 500 FEET OR AT TERMINATION OF ANY SECTION OF PIPE OR CONNECTION TO ANY EXISTING MAIN OR OTHER STRUCTURE. THE TRACER WIRE SHALL BE BROUGHT TO THE GROUND SURFACE AT ACCESS POINTS, SEE TRACER WIRE ACCESS POINT DETAIL. THE TRACER WIRE SHALL BE CONNECTED TO THE TRACER WIRE BOX LID AS RECOMMENDED BY THE MANUFACTURER. SPLICES IN THE TRACER WIRE SHOULD BE CONNECTED BY MEANS OF A HEAT SHRINK SPLICE KIT TO ENSURE CONTINUITY. WIRE NUTS SHOULD NOT BE USED.
- AFTER INSTALLATION, TRACER WIRE SHOULD BE TESTED TO VERIFY CONTINUITY OF THE TRACER WIRE SYSTEM AND A REPORT INDICATING CONTINUITY SHOULD BE SUBMITTED AS PART OF THE AS-BUILT CONSTRUCTION RECORDS.
- TRACER WIRE SHALL BE PLACED ON THE TOP SIDE OF THE PIPE. WIRE SHALL BE ATTACHED TO THE PIPE USING NYLON CABLE TIES SPACED AT TEN FOOT (10') INTERVALS.

NOTES:

- HDPE OR NON-METALIC PIPE ONLY PERMISSIBLE ON SERVICE SIDE OF CURB STOP. IN NO CASE SHALL ANYTHING OTHER THAN "K" COPPER BE USED IN THE ROADWAY OR FROM MAIN TO CURB STOP.
- HDPE SHALL BE DR-11, PE4710 (200 PSI).
- TRACER WIRE SHALL BE INSTALLED FOR ALL HDPE OR NON-METALIC PIPE AND MUST BE INSTALLED ALL THE WAY TO THE BUILDING, TO ENABLE DETECTION BY A RADIO FREQUENCY CABLE AND PIPE LOCATOR. SEE TRACER WIRE NOTES FOR SPECIFICATIONS.
- STAINLESS STEEL TAPPING SADDLES MUST BE USED FOR:
  - ACP OR PVC PIPE.
  - IN AN INSTANCE WHERE TAP IS TO BE LARGER THAN MAXIMUM TAP SIZE FOR THE MAIN.
- FOR INSTANCES WHERE A TAPPING SADDLE IS USED, TAPPING SADDLES MUST CONTAIN 100% STAINLESS STEEL PARTS AND BE RATED FOR 250 PSI MINIMUM WORKING PRESSURE, SUCH AS FORD STAINLESS STEEL STYLE FS300 OR APPROVED EQUAL AND MUST BE APPROVED PRIOR TO USE.
- CURB STOPS SHALL NOT BE LOCATED IN SIDEWALKS OR DRIVEWAYS.

M:\Projects\M180007\TYDETS\SHT25-48 DATE: APR 10, 2014 TIME: 10:45 AM

| BY  | DATE     | REVISIONS                                   |
|-----|----------|---|
| CFC | 12/17/18 | UPDATED TRACER WIRE NOTES                   |
| CFC | 12/15/17 | "SNAKEPIT BOX" DETAIL ADDED & NOTED UPDATED |
| CFC | 2/12/16  | UPDATED NOTE 3                              |
| CFC | 10/30/15 | UPDATED NOTES & ADDED SERVICE SADDLE        |
| CFC | 4/4/14   | UPDATED CORP. & CURB STOP CATALOG NO.'s     |
| CFC | 11/24/10 | REVISED PER M.L.T.M.U.A. COMMENTS           |
| CFC | 1/24/07  | REVISED NOTES & TITLE                       |
| CFC | 8/14/06  | REVISED CORP. STOP & CURB STOP NOTES        |
| FWR | 7/2/03   | ADDED NOTE 3                                |
| CFC | 9/6/02   | REVISED CORP. STOP & VALVE BOX LID          |

MOUNT LAUREL TOWNSHIP  
MUNICIPAL UTILITIES AUTHORITY

WATER MAIN  
TYPICAL SERVICE  
CONNECTION

|         |      |                 |
|---------|------|-----------------|
| DATE:   | 4/95 | SHEET NO.<br>26 |
| DWG BY: |      |                 |

M:\Projects\M180007\TYPDETS\SH25-48 DATE: APR 10, 2014 TIME: 10:45 AM

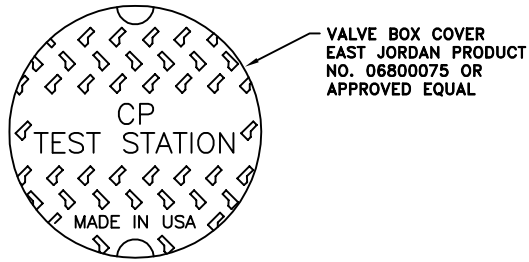

VALVE BOX COVER  
EAST JORDAN PRODUCT  
NO. 06800075 OR  
APPROVED EQUAL

TOP VIEW

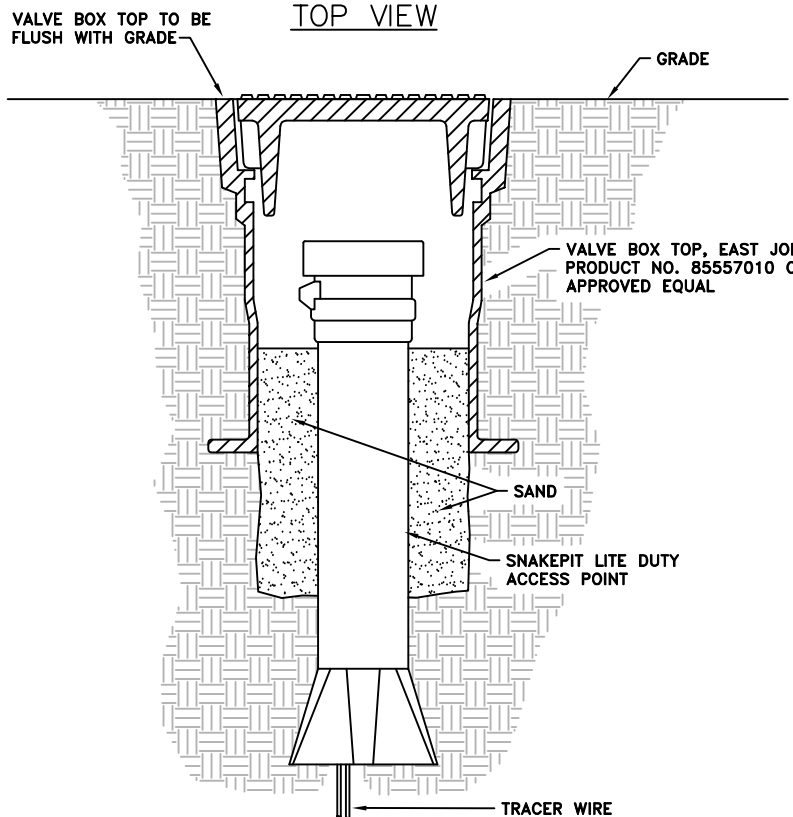

SIDE VIEW

EAST JORDAN 8557010  
VALVE BOX TOP SPECIFICATIONS  
MATERIALS - GREY IRON (CL35B)  
DESIGN LOAD - HEAVY DUTY  
COATING - DIPPED  
CERTIFICATION - ASTM A48  
COUNTRY OF ORIGIN - USA

EAST JORDAN 06800075  
VALVE BOX COVER SPECIFICATIONS  
MATERIALS - GREY IRON (CL35B)  
DESIGN LOAD - HEAVY DUTY  
COATING - DIPPED  
CERTIFICATION - ASTM A48  
COUNTRY OF ORIGIN - USA  
STAMPED - TEST STATION

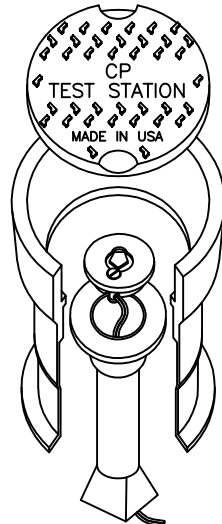

SNAKEPIT &  
VALVE BOX TOP  
ASSEMBLY

SNAKEPIT LITE DUTY BY COPPERHEAD INDUSTRIES  
ACCESS POINT SPECIFICATIONS  
HIGH-STRENGTH, IMPACT-RESISTANT RESIN LID  
ANTI-CORROSION GEL PROTECTS WIRES  
LID COLOR CODED TO MEET AMERICAN PUBLIC WORKS  
(APWA) STANDARDS FOR UTILITY IDENTIFICATION

ACCESS POINTS

- a. TRACER WIRE ACCESS POINTS SHALL BE PLACED EVERY 500 FEET OR AT TERMINATION OF ANY SECTION OF PIPE OR CONNECTION TO ANY EXISTING MAIN OR OTHER STRUCTURE.
- b. THE TRACER WIRE SHALL BE BROUGHT TO THE GROUND SURFACE AT ACCESS POINTS USING A "SNAKEPIT LITE DUTY MAGNETIZED TRACER WIRE BOX" OR APPROVED EQUAL. THE "SNAKEPIT" SHALL BE PLACED WITHIN A VALVE BOX TOP.
- c. THE "SNAKEPIT" LIDS SHALL BE COLOR CODED BASED ON USAGE: BLUE - POTABLE WATER, PURPLE - RECLAIMED WATER AND GREEN - SANITARY SEWER.
- d. THE VALVE BOX TOP COVER SHALL BE MARKED "TEST STATION".
- e. THE TRACER WIRE SHALL BE CONNECTED TO THE "SNAKEPIT" LID AS RECOMMENDED BY THE MANUFACTURER.

| BY | DATE | REVISIONS |
|----|------|-----------|
|    |      |           |
|    |      |           |
|    |      |           |
|    |      |           |

MOUNT LAUREL TOWNSHIP  
MUNICIPAL UTILITIES AUTHORITY

TRACER WIRE ACCESS  
POINT DETAIL

|         |       |                 |
|---------|-------|-----------------|
| DATE:   | 12/18 | SHEET NO.<br>50 |
| DWG BY: |       |                 |